



CULTURAL HERITAGE COMMISSION

---

# **HISTORIC-CULTURAL MONUMENT APPLICATION**



**SIGNIFICANCE WORK SHEET**

TYPE OR HAND PRINT IN ALL CAPITAL BLOCK LETTERS

*Complete One or Both of the Upper and Lower Portions of This Page*

**ARCHITECTURAL SIGNIFICANCE**

THE \_\_\_\_\_ IS AN IMPORTANT EXAMPLE OF  
NAME OF PROPOSED MONUMENT

\_\_\_\_\_  
ARCHITECTURAL STYLE (SEE LINE 8) ARCHITECTURE

AND MEETS THE CULTURAL HERITAGE ORDINANCE BECAUSE OF THE HIGH QUALITY OF ITS DESIGN AND THE RETENTION OF ITS ORIGINAL FORM, DETAILING AND INTEGRITY.

**A N D / O R**

**HISTORICAL SIGNIFICANCE**

THE \_\_\_\_\_ WAS BUILT IN \_\_\_\_\_  
NAME OF PROPOSED MONUMENT YEAR BUILT

\_\_\_\_\_  
NAME OF FIRST OR SIGNIFICANT OTHER WAS IMPORTANT TO THE

DEVELOPMENT OF LOS ANGELES BECAUSE \_\_\_\_\_  
\_\_\_\_\_  
\_\_\_\_\_  
\_\_\_\_\_  
\_\_\_\_\_

# HISTORIC-CULTURAL MONUMENT APPLICATION

TYPE OR HAND PRINT IN ALL CAPITAL BLOCK LETTERS

## IDENTIFICATION

1. NAME OF PROPOSED MONUMENT \_\_\_\_\_
2. STREET ADDRESS \_\_\_\_\_  
CITY \_\_\_\_\_ ZIP CODE \_\_\_\_\_ COUNCIL DISTRICT \_\_\_\_\_
3. ASSESSOR'S PARCEL NO. \_\_\_\_\_
4. COMPLETE LEGAL DESCRIPTION: TRACT \_\_\_\_\_  
BLOCK \_\_\_\_\_ LOT(S) \_\_\_\_\_ ARB. NO. \_\_\_\_\_
5. RANGE OF ADDRESSES ON PROPERTY \_\_\_\_\_  
\_\_\_\_\_
6. PRESENT OWNER \_\_\_\_\_  
STREET ADDRESS \_\_\_\_\_  
CITY \_\_\_\_\_ STATE \_\_\_\_\_ ZIP CODE \_\_\_\_\_ PHONE (\_\_\_\_) \_\_\_\_\_  
OWNER IS: PRIVATE \_\_\_\_\_ PUBLIC \_\_\_\_\_
7. PRESENT USE \_\_\_\_\_ ORIGINAL USE \_\_\_\_\_

## DESCRIPTION

8. ARCHITECTURAL STYLE \_\_\_\_\_  
(SEE STYLE GUIDE)
9. STATE PRESENT PHYSICAL DESCRIPTION OF THE SITE OR STRUCTURE (SEE OPTIONAL DESCRIPTION WORK SHEET)  
\_\_\_\_\_  
\_\_\_\_\_  
\_\_\_\_\_  
\_\_\_\_\_  
\_\_\_\_\_  
\_\_\_\_\_  
\_\_\_\_\_  
\_\_\_\_\_

# HISTORIC-CULTURAL MONUMENT APPLICATION

NAME OF PROPOSED MONUMENT \_\_\_\_\_

10. CONSTRUCTION DATE: FACTUAL \_\_\_\_\_ ESTIMATED \_\_\_\_\_

11. ARCHITECT, DESIGNER, OR ENGINEER \_\_\_\_\_

12. CONTRACTOR OR OTHER BUILDER \_\_\_\_\_

13. DATES OF ENCLOSED PHOTOGRAPHS \_\_\_\_\_  
(8X10 BLACK AND WHITE GLOSSY)

14. CONDITION:  EXCELLENT     GOOD     FAIR     DETERIORATED     NO LONGER IN EXISTENCE

15. ALTERATIONS \_\_\_\_\_

---

---

---

16. THREATS TO SITE:  NONE KNOWN     PRIVATE DEVELOPMENT     VANDALISM     PUBLIC WORKS PROJECT  
 ZONING     OTHER \_\_\_\_\_

17. IS THE STRUCTURE:  ON ITS ORIGINAL SITE     MOVED     UNKNOWN

## SIGNIFICANCE

18. BRIEF STATE HISTORICAL AND/OR ARCHITECTURAL IMPORTANCE: INCLUDE DATES, EVENTS, AND PERSON ASSOCIATED WITH THE SITE (SEE OPTIONAL SIGNIFICANCE WORK SHEET)

---

---

---

---

---

19. SOURCES (LIST BOOKS, DOCUMENTS, SURVEYS, PERSONAL INTERVIEWS WITH DATES) \_\_\_\_\_

---

---

20. DATE FORM PREPARED \_\_\_\_\_ PREPARER'S NAME \_\_\_\_\_

ORGANIZATION \_\_\_\_\_ STREET ADDRESS \_\_\_\_\_

CITY \_\_\_\_\_ STATE \_\_\_\_\_ ZIP CODE \_\_\_\_\_ PHONE (\_\_\_\_) \_\_\_\_\_

# DESCRIPTION WORK SHEET

TYPE OR HAND PRINT IN ALL CAPITAL BLOCK LETTERS

THE \_\_\_\_\_ IS A \_\_\_\_\_-STORY,  
NAME OF PROPOSED MONUMENT NUMBER OF STORIES

\_\_\_\_\_, \_\_\_\_\_ PLAN \_\_\_\_\_  
ARCHITECTURAL STYLE (SEE LINE 8 ABOVE) PLAN SHAPE (SEE CHART) STRUCTURE USE (RESIDENCE, ETC.)

WITH A \_\_\_\_\_ FINISH AND \_\_\_\_\_ TRIM.  
MATERIAL (WOOD SLIDING, WOOD SHINGLES, BRICK, STUCCO, ETC.) MATERIAL (WOOD, METAL, ETC.)

IT'S \_\_\_\_\_ ROOF IS \_\_\_\_\_,  
ROOF SHAPE (SEE CHART) MATERIAL (CLAY TILE, ASPHALT OR WOOD SHINGLES, ETC.) WINDOW MATERIAL

\_\_\_\_\_  
WINDOWS ARE PART OF THE DESIGN.  
WINDOW TYPE [DOUBLE-HUNG (SLIDES UP & DOWN), CASEMENT (OPENS OUT), HORIZONTAL SLIDING, ETC.]

THE ENTRY FEATURES A \_\_\_\_\_,  
DOOR LOCATION (RECESSED, CENTERED, OFF-CENTER, CORNER, ETC.)

\_\_\_\_\_  
ENTRY DOOR STYLE (SEE CHART) DOOR. ADDITIONAL CHARACTER DEFINING ELEMENTS

OF THE STRUCTURE ARE \_\_\_\_\_  
IDENTIFY **ORIGINAL FEATURES** SUCH AS PORCHES (SEE CHART); BALCONIES; NUMBER AND SHAPE OF DORMERS (SEE CHART);

\_\_\_\_\_  
NUMBER AND LOCATION OF CHIMNEYS; SHUTTERS; SECONDARY FINISH MATERIALS; PARAPETS; METAL TRIM; DECORATIVE TILE OR CAST STONE; ARCHES;

\_\_\_\_\_  
ORNAMENTAL WOODWORK; SYMMETRY OR ASYMMETRY; CORNICES; FRIEZES; TOWERS OR TURRETS; BAY WINDOWS; HALFTIMBERING; HORIZONTALLY;

\_\_\_\_\_  
VERTICALLY; FORMALITY OR INFORMALITY; GARDEN WALLS, ETC.

SECONDARY BUILDINGS CONSIST OF A \_\_\_\_\_  
IDENTIFY GARAGE; GARDEN SHELTER, ETC.

SIGNIFICANT INTERIOR SPACES INCLUDE \_\_\_\_\_  
IDENTIFY **ORIGINAL FEATURES** SUCH AS WOOD PANELING; MOLDINGS AND TRIM; SPECIAL GLASS WINDOWS;

\_\_\_\_\_  
ORNATE CEILINGS; PLASTER MOLDINGS; LIGHT FIXTURES; PAINTED DECORATION; CERAMIC TILE; STAIR BALUSTRADES; BUILT-IN FURNITURE, ETC.

IMPORTANT LANDSCAPING INCLUDES \_\_\_\_\_  
IDENTIFY NOTABLE MATURE TREES AND SHRUBS

## STYLE GUIDE



**CLASSICAL REVIVAL**  
1840-1870

- Pedimented gable roof
- Wood siding
- Transomed windows
- Fan-lighted entry door
- Two-story
- Balconies/porches
- Square columns
- Symmetry



**EASTLAKE REVIVAL**  
1870-1890

- Multi-planed roof
- Panelized siding
- Bay windows
- Projecting brackets
- Fish scale shingles
- Panel divided walls
- Exposed structure
- Fragile woodwork



**ITALIANATE**  
1870-1890

- Low hip/flat roof
- Wood siding
- Double-hung windows
- Ornate eave brackets
- Door/window headers
- Long porches
- Quoined corners
- Spindled balustrades



**QUEEN ANNE**  
1880-1900

- Multi-planed roof
- Horizontal siding
- Double-hung windows
- Round corner tower
- Classical detailing
- Corner porch/balcony
- Tactile decoration
- Asymmetry



**CHAUTEAUESQUE**  
1890-1915

- High-pitched roof
- Plaster walls
- Gothic doors/windows
- Round corner turrets
- Pedimented parapets
- Arched entryway
- Dormers
- Asymmetry



**COLONIAL REVIVAL**  
1890-1915

- Gable or hip roof
- Clapboard walls
- Double-hung windows
- Small-paned glazing
- Classical detailing
- Rectangular volumes
- Pedimented dormers
- Symmetry



**MISSION REVIVAL**  
1890-1915

- Low-pitched tile roof
- Plain plaster walls
- Arched doors/windows
- White surfaces
- Scalloped parapets
- Small balconies
- Islamic ornamentation
- Occasional dome



**CRAFTSMAN**  
1900-1925

- Gable or hip roof
- Plaster or wood walls
- Double-hung windows
- Simple boxlike shapes
- Informality
- Brick porch/chimney
- Exposed rafters
- Asymmetry



**FRENCH NORMAN**  
1915-1940

- High hip roof
- Plaster/brick walls
- Narrow windows
- Round corner tower
- Half-timbering
- El shaped plan
- Dormers
- Farmhouse inspired



**MONTEREY REVIVAL**  
1915-1940

- Low gable roof
- Plaster walls
- Large paned windows
- Rectilinear volumes
- Shingle or tile roofing
- Projecting balcony
- Wood railings
- Shutters



**SPANISH COLONIAL REVIVAL**  
1915-1940

- Low-pitched tile roof
- Plaster walls
- Recessed windows
- Few openings
- Decorative iron work
- Indoor/outdoor tie
- Glazed tile decoration
- Formal gardens



**ENGLISH TUDOR REVIVAL**  
1915-1940

- High intersecting gables
- Plaster/brick walls
- Multi-paned casements
- Arched entryway
- Half-timbering
- Porch/balcony
- Tall chimney
- Informal gardens



**ART DECO**  
1920-1940

- Flat roof
- Smooth volumes
- Recessed windows
- Receding center tower
- Monumentality
- Verticality
- Zig-Zag ornamentation
- Symmetry



**INTERNATIONAL**  
1925-1940









- Flat roof
- Smooth plaster walls
- Expansive glass
- Closed eaves
- Cantilevers/lightness
- Walls/glass in plane
- Machine image
- Horizontality









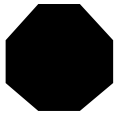



**STREAMLINE MODERNE**  
1935-1945

- Flat roof
- Smooth plaster walls
- Banded windows
- Rounded corners
- Glass block
- Curving steel railings
- No ornamentation
- Horizontality







**PLAN** – The basic shape of the building (including wings and additions) as seen from above. List the closest one – don't worry about minor projections such as bay windows or email porches.

									
1. SQUARE	2. RECTANGULAR	3. CENTER SPACE	4. L SHAPE	5. T SHAPE	6. U SHAPE	7. H SHAPE	8. CROSS-AXIAL	9. IRREGULAR	10. POLYGONAL





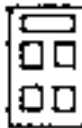

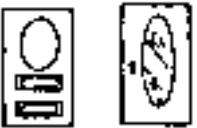
**ROOF SHAPE** – *Multiple Choice* Mark the shape which most closely resembles the building's roof. If several types are combined on the building, treat this as multiple choice.

									
4. MEDIUM GABLE	6. CENTER GABLE	7. OFFSET GABLE	8. CROSS GABLE	13. MEDIUM GABLE	17. GABLET	18. GAMBREL	21. MANSARD	26. SHED	27. SALTBOX



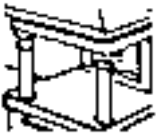

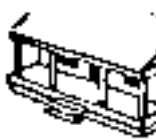





**MAIN DOOR TYPE** – *Multiple Choice* Indicate the type of doors within the main doorway opening. The panels in the illustration may be blind (no glass) or may be glass panels. Do not be limited by the drawing; panels can be used in a variety of arrangements. Select the example which is most similar to the main door of the building.

						
6. SINGLE PANEL	7. TWO PANEL	8. THREE PANEL	9. FOUR PANEL	10. FIVE PANEL	11. SIX OR MORE PANELS	13. DOOR WITH GLASS OVAL OR CIRCLE

**MAIN PORCH** – May cover one or more stories in height.

						
3. STOOP	4. RECESSED INTO WALL OR INTO CORNER	5. OPEN PORCH WITH SQUARE POSTS OR ROUND COLUMNS	6. PORCH WITH STICKWORK	8. OPEN VERANDA (EXTENDS ACROSS FRONT, SOMETIMES AROUND SIDES)	9. CLOSED VERANDA	10. GUYED (SUPPORTED BY CABLES FROM ABOVE)

**DORMER SHAPE** – A dormer is a window or a louvered vent section which projects above the slope of the roof.

									
3. GABLE, NO OVERHANG	4. GABLE, WITH OVERHAND	5. GABLE, WITH RETURN	6. GABLE, WITH PEDIMENT	11. SWEPT	12. HOODED	13. HIPPED	14. HIPPED GABLE	15. GABLET	16. SHED